

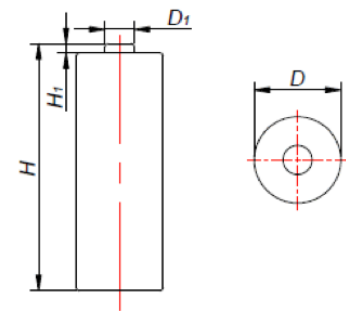

## Accus Nimh industriels SC 1.2V 3800mAh FT

### MAIN INFORMATION | INFORMATIONS GÉNÉRALES

Brand   Marque	<b>NX</b>
Technology   Technologie	<b>NICKEL METAL HYDRIDE BATTERY ACCUMULATEUR NIMH</b>
Voltage   Tension	<b>1,2V</b>
Charge standard	<b>380mA x 14h</b>
Capacity   Capacité	<b>3800mAh</b>
Minimal Capacity   Capacité mini	<b>3800mAh/0.2C</b>
Tension de charge maxi   Max continuous charge voltage	<b>1,6V</b>
Cycle life at 80% DOD (0,5C)	<b>500</b>
Résistance Interne   Internal Impedance	<b>18mΩ</b>
<b>Température d'usage   Ambient temperature</b>	
Charge   Charging	<b>0~40°C(32 to 104°F)</b>
Décharge   Discharging	<b>-20~55°C(-4 to 131°F)</b>
Température de stockage   Storage temperature	<b>-20°C~45°C(-4 to 113°F)</b>
Charge rapide   Fast charge	<b>1900mA x 140min</b>



← DIMENSIONS | DIMENSIONS →

**D: 22.5-23.2mm**

**H: 42.5-43.5mm**

**D1: 10.0 ± 0.2mm**

**H1: 0.5 ± 0.3mm**



Weight Battery | Poids batterie

**61g**

### COURBES DE CHARGE

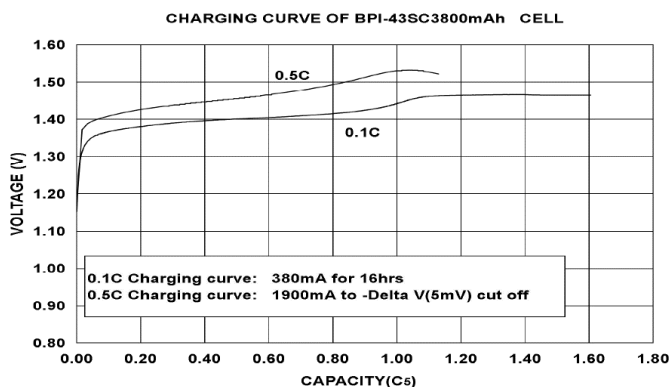

### COURBES DE DÉCHARGE

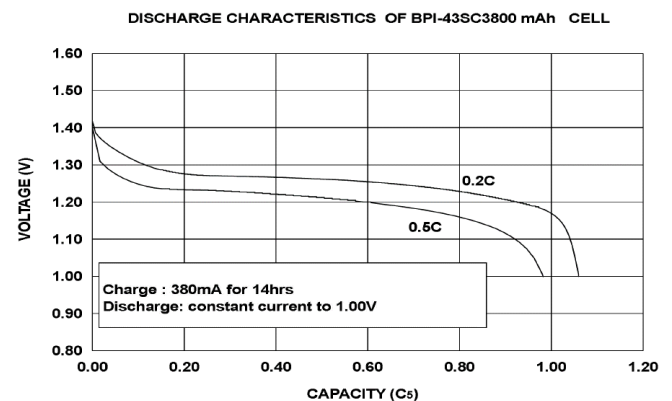

OUTLINE SAFETY WARNING: USE ONLY WITH IN THE ALLOWED PARAMETERS. Do not short circuit or over-load the battery. Charge only using an approved charger designed specifically to charge this battery. Do not heat above maximum temperatures indicated. Never crush, mutilate, puncture or abuse the battery. Do not dismantle the pack or disable any of the protective devices or circuits. DO NOT USE THE BATTERY IF YOU SUSPECT IT MAY BE FAULTY OR DAMAGED.

No document or design may be copied or used for commercial purposes without written permission of Enix Energies. Users must satisfy themselves, by means of testing etc., that products are suitable for their application. Data in this document is for general guidance only; consult cell manufacturers data for definitive information. Information is given free of charge and in good faith, but no responsibility can be accepted for any errors or omission or costs or losses or liabilities arising from the use of this information. All business is conducted to Enix Energies terms and conditions only.

