



# UPS HIGH RATE FRONT TERMINAL BATTERY

## BATTERIE UPS HIGH RATE FRONT TERMINAL

### 12FTA-55 UPS HIGH RATE M6-F



#### MAIN INFORMATION / INFORMATIONS GÉNÉRALES

<b>BRAND</b>	MARQUE	NX
<b>TECHNOLOGY</b>	TECHNOLOGIE	AGM Lead acid / Plomb AGM
<b>VOLTAGE</b>	TENSION	12V
<b>NOMINAL CAPACITY</b>	CAPACITÉ NOMINALE	55Ah (10h) 48Ah (5h) 34Ah (1h)
<b>DIMENSIONS (±2mm)</b>	DIMENSIONS (±2mm)	
• <b>Length / Longueur</b>		277mm
• <b>Width / Largeur</b>		106mm
• <b>Height / Hauteur</b>		221mm
• <b>Total height with terminals / Hauteur totale (avec cosses)</b>		221mm
<b>WEIGHT</b>	POIDS	16.8kg
<b>TERMINAL</b>	BORNES	M6-F

#### TECHNICAL INFORMATION / INFORMATIQUES TECHNIQUES

<b>MAXD DISCHARGE CURRENT</b>	COURANT DE DÉCHARGE MAX	500A (5s)
<b>MAX CHARGING CURRENT</b>	COURANT DE CHARGE	17.5A
<b>INTERNAL RESISTANCE</b>	RÉSISTANCE INTERNE	Approx. 6.5mΩ
<b>OPERATING TEMPERATURE RANGE</b>	PLAGE DE TEMPÉRATURE	
• <b>Discharging / Décharge</b>		-15°C~50°C (5°F~122°F)
• <b>Charging / Charge</b>		-10°C~50°C (14°F~122°F)
• <b>Storage / Stockage</b>		-20°C~50°C (-4°F~122°F)
<b>NOMINAL OPERATING TEMPERATURE</b>		25°C±3°C(77°F±5°F)
<b>PLAGE DE TEMPÉRATURE</b>		
<b>CAPACITY VS TEMPERATURE</b>	CAPACITÉ SELON LA TEMPÉRATURE	40°C: 102% 25°C: 100% 0°C: 85% -15°C: 65%

#### TERMINAL: M6-F

Unit: mm / Unité: mm

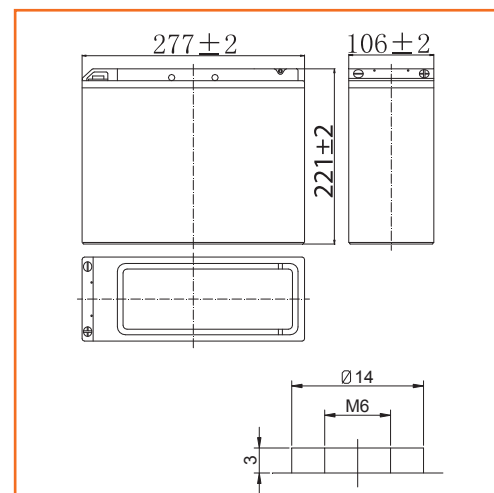

#### APPLICATIONS

POWER CABINETS / ARMOIRES ÉLECTRIQUES

TELECOMS / TÉLÉCOMMUNICATIONS

UPS / ONDULEURS

POWER SUPPLY / RÉSERVE D'ÉNERGIE

RAILWAY AND MARINE SIGNAL / SIGNALISATION FERROVIAIRE ET MARINE

<b>TMD 1 DESCRIPTION, CLASSE: 2800</b>	
<b>ADR:</b> Not regulated	<b>IMDG:</b> Not regulated
<b>IATA:</b> Exempt	<b>PROCÉDURE TMD:</b> Proc 2 UN2800



**CONSTANT CURRENT DISCHARGE CHARACTERISTICS (A, 25°C)**  
**CARACTÉRISTIQUES DE DÉCHARGE À COURANT CONSTANT (A, 25°C)**

F.V/TIME	15min	30min	60min	2h	3h	4h	5h	6h	8h	10h	20h
9.60V/cell	88.9	53.9	34.1	20.1	14.9	11.5	9.82	8.58	6.73	5.65	2.94
9.90V/cell	86.8	52.8	39.2	20.0	14.8	11.4	9.76	8.53	6.69	5.62	2.93
10.2V/cell	83.6	51.2	36.7	19.8	14.6	11.4	9.69	8.47	6.65	5.61	2.93
10.5V/cell	80.8	50.0	33.7	19.5	14.6	11.3	9.63	8.42	6.60	5.61	2.91
10.8V/cell	76.5	48.1	31.1	19.0	13.3	10.9	9.34	8.16	6.40	5.50	2.89

**CONSTANT POWER DISCHARGE CHARACTERISTICS (WATT, 25°C)**  
**CARACTÉRISTIQUES DE DÉCHARGE À PUISSANCE CONSTANTE (WATT, 25°C)**

F.V/TIME	15min	30min	60min	2h	3h	4h	5h	6h	8h	10h	20h
9.60V/cell	977	605	389	233	165	135	116	101	80.0	67.9	35.3
9.90V/cell	953	593	383	231	164	134	115	101	79.5	67.4	35.2
10.2V/cell	918	585	373	229	163	134	115	100	79.0	67.3	35.1
10.5V/cell	887	586	367	226	162	133	114	99.5	78.4	67.3	34.9
10.8V/cell	864	582	363	220	157	129	110	96.5	76.1	65.7	34.7

**DISCHARGE CHARACTERISTICS(25°C)**  
**CARACTÉRISTIQUES DE DÉCHARGE (25°C)**

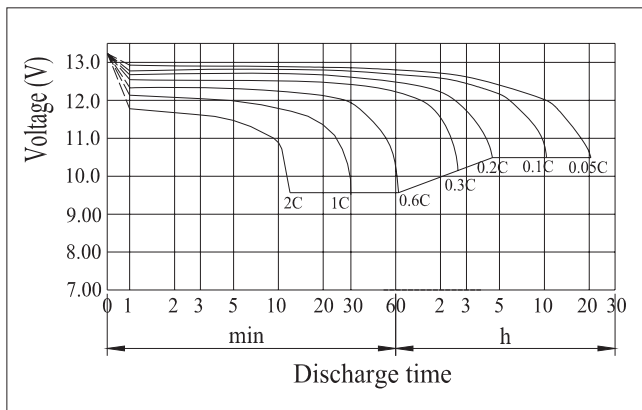

**CHARGING CHARACTERISTICS(25°C)**  
**CARACTÉRISTIQUES DE CHARGE (25°C)**

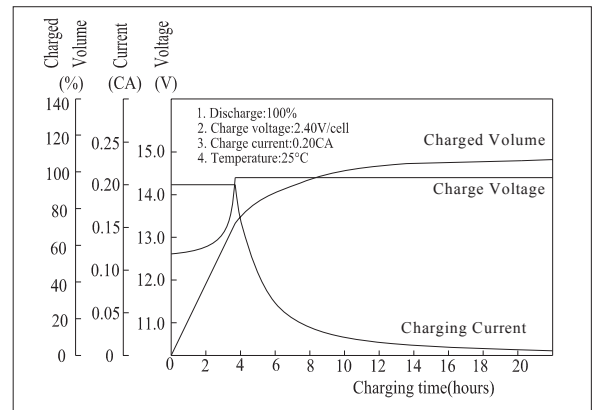

**EFFECT OF TEMPERATURE ON CAPACITY**  
**EFFET DE LA TEMPÉRATURE SUR LA CAPACITÉ**

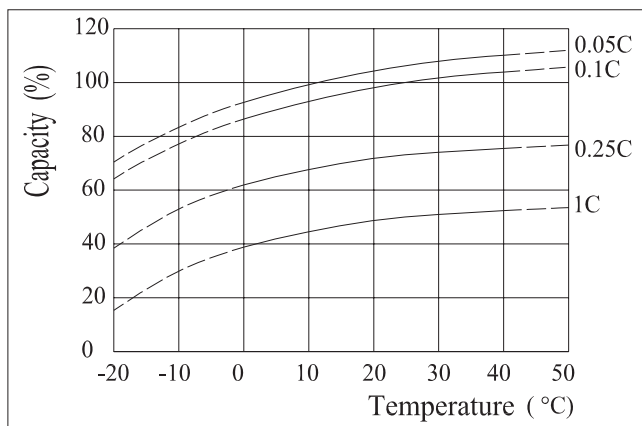

**SELF-DISCHARGE CHARACTERISTICS**  
**CARACTÉRISTIQUES D'AUTO-DÉCHARGE**

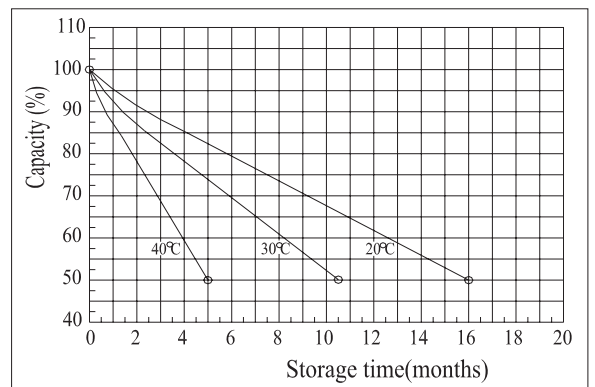

<b>TMD 1 DESCRIPTION, CLASSE: 2800</b>	
<b>ADR:</b> Not regulated	<b>IMDG:</b> Not regulated
<b>IATA:</b> Exempt	<b>PROCÉDURE TMD:</b> Proc 2 UN2800



**THE RELATIONSHIP FOR OPEN CIRCUIT VOLTAGE AND RESIDUAL CAPACITY (25°C)**  
 LA RELATION ENTRE LA TENSION EN CIRCUIT OUVERT ET LA CAPACITÉ RÉSIDUELLE (25°C)

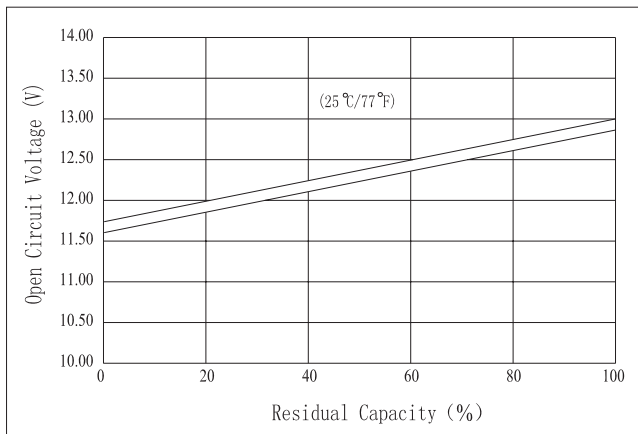

**THE RELATIONSHIP FOR CHARGING VOLTAGE AND TEMPERATURE**  
 LA RELATION ENTRE LA TENSION ET LA TEMPÉRATURE DE CHARGE

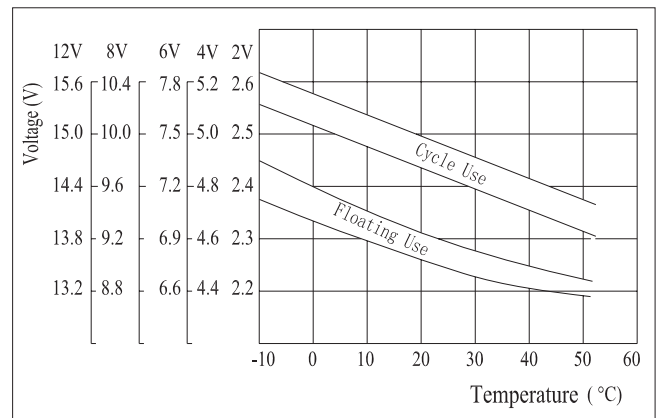

**FLOATING LIFE ON TEMPERATURE**  
 DURÉE DE VIE EN FLOATING À TEMPÉRATURE

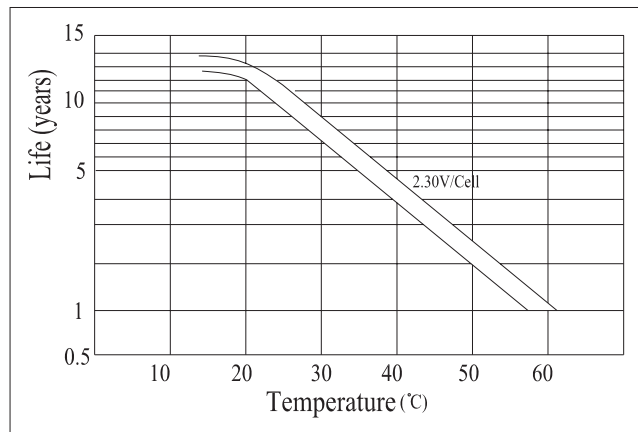

**CYCLE LIFE ON D.O.D (25°C)**  
 CYCLE DE VIE SUR D.O.D (25°C)

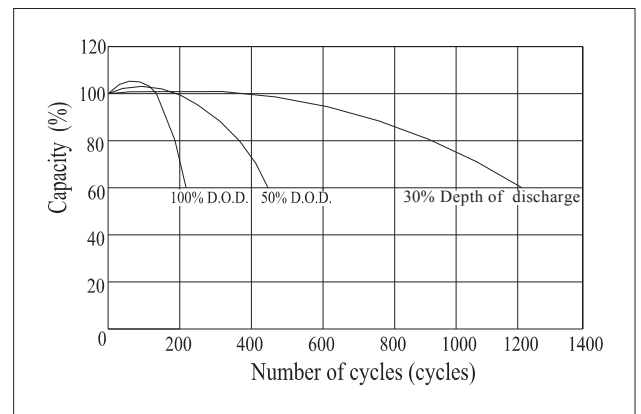

<b>TMD 1 DESCRIPTION, CLASSE: 2800</b>	
<b>ADR:</b> Not regulated	<b>IMDG:</b> Not regulated
<b>IATA:</b> Exempt	<b>PROCÉDURE TMD:</b> Proc 2 UN2800

