



GEL LEAD ACID BATTERY NX 60-12 CYCLIC

BATTERIE PLOMB ÉTANCHE GEL NX 60-12 CYCLIC

12V 60Ah M6-F



MAIN INFORMATION / INFORMATIONS GÉNÉRALES

BRAND	MARQUE	NX
TECHNOLOGY	TECHNOLOGIE	Plomb étanche gel - Gel lead acid
NOMINAL VOLTAGE	TENSION NOMINALE	12V
NOMINAL CAPACITY	CAPACITÉ NOMINALE	60Ah
DIMENSIONS	DIMENSIONS	
• Length / Longueur		255 (10.0 inches)
• Width / Largeur		170 (6.69 inches)
• Height / Hauteur		174,5 (6.87 inches)
• Total height with terminals / Hauteur totale (avec cosSES)		177,5 (6.99 inches)
WEIGHT (± 4 %)	POIDS (± 4 %)	Approx 18,05kg
TERMINAL	TYPE DE COSSES	M6-F
CASING	TYPE DE BAC	ABS
COLOR	COULEUR DE BAC	Grey top and white case



TECHNICAL INFORMATION / INFORMATIONS TECHNIQUES

CAPACITY	CAPACITÉ	60.0Ah (20hr,3.00A,1.80V/cell) 50.0Ah (10hr,5.00A,1.80V/cell) 47.5Ah (5hr,9.50A,1.75V/cell) 44.1Ah (3hr,14.7A,1.75V/cell) 34.4Ah (1hr,34.4A,1.67V/cell)
DISCHARGE CURRENT	COURANT DE DÉCHARGE	600A (5s)
INTERNAL RESISTANCE	RÉSISTANCE INTERNE	Approx 9.8mΩ
OPERATING TEMPERATURE RANGE	PLAGE DE TEMPÉRATURE	
• Discharging / Décharge		-20°~55°C (-4 ~131°F)
• Charging / Charge		0°~40°C (-4 ~104°F)
• Storage / Stockage		-20°~50°C (-4 ~122°F)
NOMINAL OPERATING TEMPERATURE	TEMPÉRATURE D'UTILISATION	25 ± 3°C (77 ± 5°F)
CYCLE USE	RECHARGE POUR UNE UTILISATION EN CYCLE	Initial Charging Current less than 12,5A. Voltage 14.4V~14,7V at 25°C(77°F) Temp. Coefficient -30mV/°C
STANDBY USE	UTILISATION EN STANDBY	Initial Charging Current less than 12,5A. Voltage 13,5V~13,8V at 25°C(77°F) Temp. Coefficient -20mV/°C
CAPACITY VS TEMPERATURE	CAPACITÉ SELON LA TEMPÉRATURE	40°C (104°F) 103% 25°C (77°F) 100% 0°C (32°F) 86%



M6-F / Terminal

Unité : mm / Unit: inches

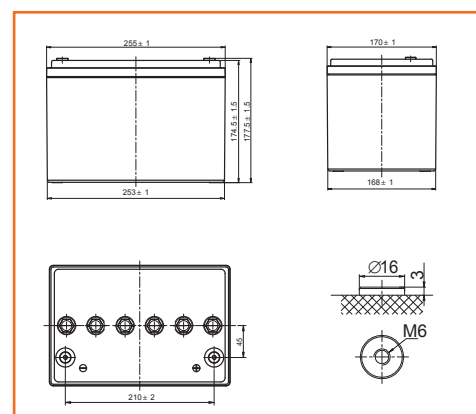

APPLICATIONS / APPLICATIONS

Electrically powered wheelchair / Fauteuil roulant électrique
Lawn-mower / Tondeuse à gazon
Golf trolleys and golf cart / Chariots de golf et voiturettes de golf

Railway and marine systems / Infrastructures ferroviaires et maritimes

CONSTANT CURRENT DISCHARGE (AMPERES) AT 25°C
TABLE DE DÉCHARGE À COURANT ET PUISSANCE CONSTANTS (A) À 25°C

F.V/Time	1h	2h	3h	4h	5h	6h	8h	10h	20h
1.85V/cell	26.4	16.2	12.9	10.4	8.75	7.46	5.84	4.90	2.79
1.80V/cell	29.2	17.9	14.1	11.3	9.21	7.89	6.08	5.00	3.00
1.75V/cell	32.7	19.2	14.7	11.7	9.50	8.14	6.18	5.15	3.03
1.67V/cell	34.4	19.9	15.1	11.9	9.75	8.27	6.29	5.20	3.05
1.60V/cell	35.5	20.3	15.3	12.1	9.95	8.41	6.35	5.25	3.08

CONSTANT POWER DISCHARGE (WATTS) AT 25°C
DÉCHARGE À PUISSANCE CONSTANTE (WATTS) À 25°C

F.V/Time	1h	2h	3h	4h	5h	6h	8h	10h	20h
1.85V/cell	51.2	31.7	25.2	20.5	17.2	14.7	11.6	9.73	5.36
1.80V/cell	56.3	34.7	27.5	22.1	18.0	15.5	12.0	9.91	5.76
1.75V/cell	62.7	37.0	28.6	22.7	18.5	16.0	12.2	10.2	5.82
1.67V/cell	65.2	38.2	29.2	23.0	19.0	16.2	12.3	10.3	5.88
1.60V/cell	66.6	38.7	29.4	23.3	19.3	16.3	12.4	10.3	5.95

DISCHARGE CHARACTERISTICS
CARACTÉRISTIQUES DE DÉCHARGE

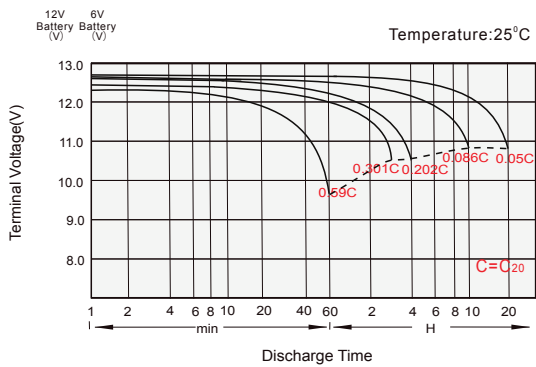

CHARGING CHARACTERISTICS
COURANT DE DÉCHARGE

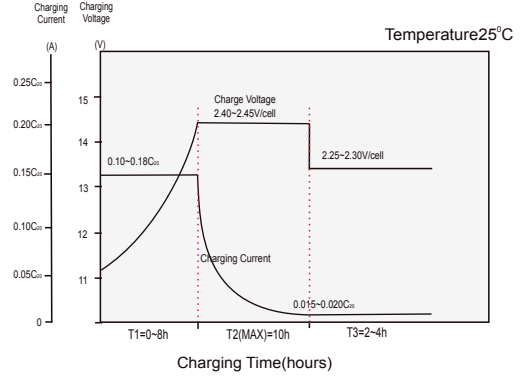

CYCLE LIFE IN RELATION TO DEPTH OF DISCHARGE
CYCLE DE VIE EN FONCTION DE LA PROFONDEUR DE LA DÉCHARGE

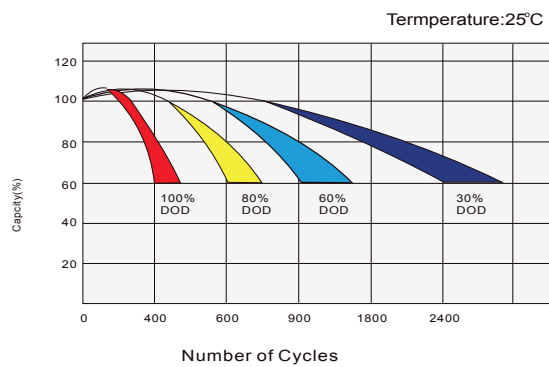

EFFECT OF TEMPERATURE ON LONG TERM FLOAT LIFE
EFFET DE LA TEMPÉRATURE SUR LA DURÉE DE VIE EN FLOATING

