



AGM LEAD ACID BATTERY

3.5-4 General Purpose F4.8



MAIN INFORMATION / INFORMATIONS GÉNÉRALES

BRAND / MARQUE	NX
TECHNOLOGY / TECHNOLOGIE	AGM Lead acid
NOMINAL VOLTAGE / TENSION NOMINALE	4V
NOMINAL CAPACITY / CAPACITÉ NOMINALE	3.5Ah (20hr)
DIMENSIONS / DIMENSIONS	
• Length / Longueur	90 ± 1mm (3.54 inches)
• Width / Largeur	34 ± 1mm (1.34 inches)
• Height / Hauteur	59 ± 1mm (2.32 inches)
• Total height with terminals / Hauteur totale (avec cosSES)	65 ± 1mm (2.56 inches)
WEIGHT (± 4 %) / POIDS (± 4 %)	Approx 0.45kg (0.99lbs)
TERMINAL / TYPE DE COSSES	F4.8=FASTON 4.8
CASING / TYPE DE BAC	UL94 V-0 (Flame retardant)
COLOR / COULEUR DE BAC	Black top and black case



TECHNICAL INFORMATION / INFORMATIONS TECHNIQUES

CAPACITY / CAPACITÉ	3.50Ah/0.175A (20hr, 1.80V/cell, 25°C/77°F) 3.26Ah/0.326A (10hr, 1.80V/cell, 25°C/77°F) 2.94Ah/0.588A (5hr, 1.75V/cell, 25°C/77°F) 2.57Ah/0.856A (3hr, 1.75V/cell, 25°C/77°F) 2.12Ah/2.12A (1hr, 1.60V/cell, 25°C/77°F)
DISCHARGE CURRENT / COURANT DE DÉCHARGE	52.5A (5s)
INTERNAL RESISTANCE / RÉSISTANCE INTERNE	Approx 14mΩ
OPERATING TEMPERATURE RANGE / PLAGES DE TEMPÉRATURE	
• Discharging / Décharge	-15°~50°C (5 ~122°F)
• Charging / Charge	0°~40°C (32 ~104°F)
• Storage / Stockage	-15°~40°C (5 ~104°F)
NOMINAL OPERATING TEMPERATURE / TEMPÉRATURE D'UTILISATION	25 ± 3°C (77 ± 5°F)
CAPACITY VS TEMPERATURE / CAPACITÉ SELON LA TEMPÉRATURE	40°C (104°F) 103% 25°C (77°F) 100% 0°C (32°F) 86%

Terminal

Unité : mm / Unit: inches

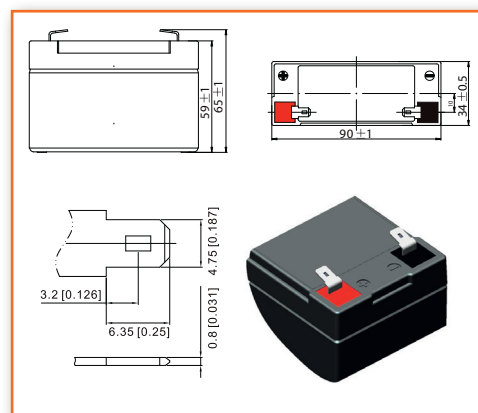

APPLICATIONS

All purpose / Tout usage
UPS / Onduleur
Emergency light / Éclairage de secours
Railway signal / Signalisation ferroviaire
Alarm and security system / Alarme et sécurité

Aircraft signal / Signal d'avion
Electronic devices and equipment / Appareils et équipements électroniques
Emergency backup / Alimentation de secours
Power supply / Réserve d'énergie

TMD 1 Description, classe : UN 2800 – accumulateurs inversables remplis d'électrolyte liquide, 8, none, (E)	
ADR : Not regulated	IMDG Not regulated
IATA : Exempt	Procédure TMD PROC 2 : UN 2800



CONSTANT CURRENT DISCHARGE (AMPERES) AT 25°C
TABLE DE DÉCHARGE À COURANT ET PUISSANCE CONSTANTS (A) À 25°C

F.V/Temps	5min	10min	15min	20min	30min	45min	1h	2h	3h	4h	5h	6h	8h	10h	20h
1.85V/cell	6.72	4.68	3.86	3.35	2.69	2.07	1.69	1.03	0.786	0.647	0.549	0.475	0.378	0.314	0.173
1.80V/cell	8.26	5.59	4.48	3.79	2.98	2.25	1.82	1.10	0.827	0.680	0.573	0.496	0.392	0.326	0.175
1.75V/cell	9.79	6.32	4.94	4.13	3.18	2.39	1.91	1.14	0.856	0.701	0.588	0.509	0.403	0.332	0.177
1.70V/cell	11.11	6.97	5.35	4.43	3.34	2.49	2.00	1.19	0.884	0.718	0.603	0.521	0.409	0.337	0.180
1.65V/cell	12.25	7.50	5.66	4.65	3.48	2.59	2.08	1.23	0.907	0.733	0.616	0.531	0.415	0.342	0.182
1.60V/cell	12.85	7.81	5.89	4.80	3.58	2.64	2.12	1.27	0.929	0.752	0.629	0.541	0.424	0.348	0.183

CONSTANT POWER DISCHARGE (WATTS) AT 25°C
DÉCHARGE À PUISSANCE CONSTANTE (WATTS) À 25°C

F.V/Temps	5min	10min	15min	20min	30min	45min	1h	2h	3h	4h	5h	6h	8h	10h	20h
1.85V/cell	12.7	8.92	7.43	6.49	5.24	4.05	3.33	2.04	1.56	1.29	1.10	0.954	0.760	0.634	0.350
1.80V/cell	15.4	10.5	8.54	7.29	5.76	4.39	3.57	2.16	1.63	1.35	1.14	0.989	0.784	0.652	0.352
1.75V/cell	18.0	11.8	9.33	7.87	6.11	4.64	3.73	2.24	1.68	1.38	1.16	1.01	0.800	0.661	0.353
1.70V/cell	20.2	12.9	10.0	8.39	6.38	4.79	3.87	2.32	1.73	1.41	1.18	1.03	0.807	0.668	0.357
1.65V/cell	22.0	13.7	10.5	8.72	6.59	4.94	4.00	2.37	1.76	1.43	1.20	1.04	0.816	0.674	0.360
1.60V/cell	22.7	14.1	10.8	8.89	6.71	5.01	4.06	2.43	1.79	1.46	1.22	1.06	0.829	0.682	0.361

DISCHARGE CHARACTERISTICS
CARACTÉRISTIQUES DE DÉCHARGE

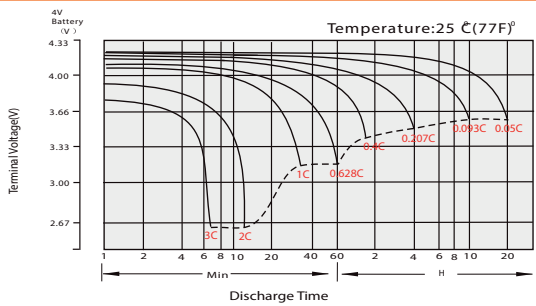

FLOAT CHARGING CHARACTERISTICS
CARACTÉRISTIQUES DE CHARGE EN FLOATING

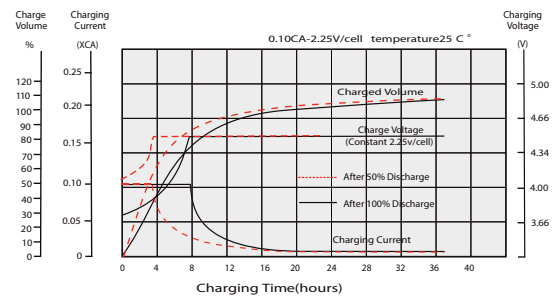

TEMPERATURE EFFECTS IN RELATION TO BATTERY CAPACITY
EFFET DE LA TEMPÉRATURE SUR LA BATTERIE

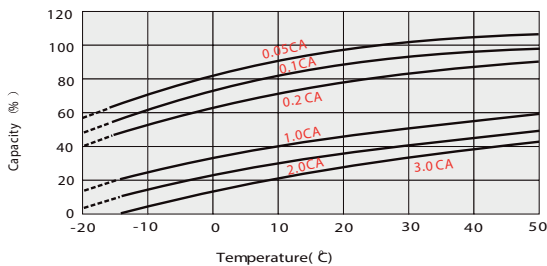

EFFECT OF TEMPERATURE ON LONG TERM FLOAT LIFE
EFFET DE LA TEMPÉRATURE SUR LA DURÉE DE VIE EN FLOATING

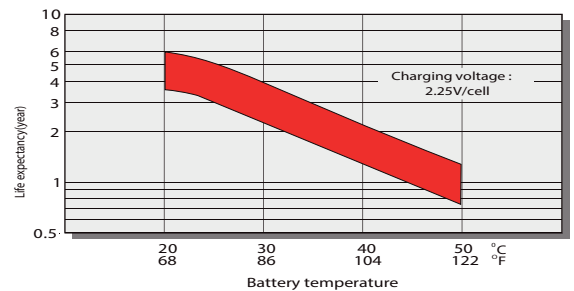

CYCLE LIFE IN RELATION TO DEPTH OF DISCHARGE
CYCLE DE VIE EN FONCTION DE LA PROFONDEUR DE LA DÉCHARGE

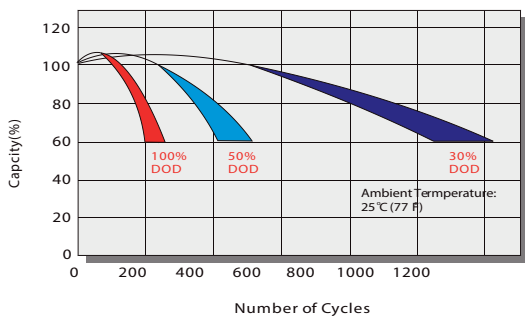

SELF DISCHARGE CHARACTERISTICS
RELATION ENTRE LA CAPACITÉ ET LE TEMPS DE STOCKAGE

