



# AGM LEAD ACID BATTERY

## G 12V-31Ah



### MAIN INFORMATION / INFORMATIONS GÉNÉRALES

<b>BRAND / MARQUE</b>	NX
<b>TECHNOLOGY / TECHNOLOGIE</b>	Gel Lead Acid
<b>NOMINAL VOLTAGE / TENSION NOMINALE</b>	12V
<b>NOMINAL CAPACITY / CAPACITÉ NOMINALE</b>	31Ah (20hr)
<b>DIMENSIONS / DIMENSIONS</b>	
• <b>Length / Longueur</b>	195 ± 2mm (7.68 inches)
• <b>Width / Largeur</b>	130 ± 2mm (5.12 inches)
• <b>Height / Hauteur</b>	164 ± 2mm (6.46 inches)
• <b>Total height with terminals / Hauteur totale (avec cosSES)</b>	183 ± 2mm (6.57 inches)
<b>WEIGHT (± 4 %) / POIDS (± 4 %)</b>	Approx 10.7kg (23.6lbs)
<b>TERMINAL / TYPE DE COSSES</b>	T5
<b>CASING / TYPE DE BAC</b>	UL94 HB (Standard ABS)
<b>COLOR / COULEUR DE BAC</b>	Grey top and white case



Photo non contractuelle

### TECHNICAL INFORMATION / INFORMATIONS TECHNIQUES

<b>CAPACITY / CAPACITÉ</b>	31.0Ah / 1.50A (20hr, 1.80V/cell, 25°C/77°F) 27.0Ah / 2.70A (10hr, 1.75V/cell, 25°C/77°F) 24.0Ah / 4.80A (5hr, 1.75V/cell, 25°C/77°F) 20.1Ah / 6.69A (3hr, 1.75V/cell, 25°C/77°F) 17.1Ah / 17.1A (1hr, 1.67V/cell, 25°C/77°F)
<b>DISCHARGE CURRENT / COURANT DE DÉCHARGE</b>	300A (5s)
<b>INTERNAL RESISTANCE / RÉSISTANCE INTERNE</b>	Approx 14.6mΩ
<b>OPERATING TEMPERATURE RANGE / PLAGES DE TEMPÉRATURE</b>	
• <b>Discharging / Décharge</b>	-15°~50°C (5 ~122°F)
• <b>Charging / Charge</b>	0°~40°C (32 ~104°F)
• <b>Storage / Stockage</b>	-15°~40°C (5 ~104°F)
<b>NOMINAL OPERATING TEMPERATURE / TEMPÉRATURE D'UTILISATION</b>	25 ± 3°C (77 ± 5°F)
<b>CAPACITY VS TEMPERATURE / CAPACITÉ SELON LA TEMPÉRATURE</b>	40°C (104°F) 103% 25°C (77°F) 100% 0°C (32°F) 86%

#### T5 / Terminal

Unité : mm / Unit: inches

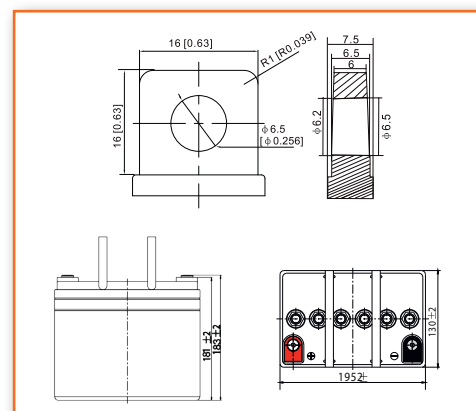

### APPLICATIONS

- Telecommunications / Télécoms
- Solar system / Système d'énergie solaire
- Wind power system / Système d'énergie éolienne
- Engine starting / Démarrage
- Wheelchair / Fauteuil roulant
- Cleaning machines / Autolaveuses
- Golf trolley / Chariots de golf
- Boats / Bateaux



**CONSTANT CURRENT DISCHARGE (AMPERES) AT 25°C**  
**TABLE DE DÉCHARGE À COURANT ET PUISSANCE CONSTANTS (A) À 25°C**

F.V./Temps	20min	30min	45min	1h	2h	3h	4h	5h	6h	7h	8h	9h	10h	20h
1.85V/cell	25.4	19.9	15.2	13.2	8.07	6.15	5.09	4.40	3.80	3.36	3.03	2.77	2.53	1.44
1.80V/cell	29.1	22.3	16.8	14.6	8.73	6.59	5.40	4.62	3.99	3.52	3.18	2.91	2.65	1.50
1.75V/cell	32.7	24.5	18.1	15.6	9.26	6.96	5.66	4.80	4.13	3.64	3.28	3.00	2.70	1.53
1.70V/cell	35.2	26.2	19.2	16.5	9.81	7.25	5.84	4.95	4.27	3.76	3.38	3.08	2.76	1.55
1.67V/cell	36.6	27.2	19.9	17.1	10.1	7.48	5.99	5.05	4.34	3.82	3.43	3.12	2.80	1.56
1.60V/cell	39.7	29.2	21.4	18.2	10.5	7.78	6.21	5.21	4.45	3.90	3.49	3.19	2.85	1.59

**CONSTANT POWER DISCHARGE (WATTS) AT 25°C**  
**DÉCHARGE À PUISSANCE CONSTANTE (WATTS) À 25°C**

F.V./Temps	20min	30min	45min	1h	2h	3h	4h	5h	6h	7h	8h	9h	10h	20h
1.85V/cell	48.6	38.4	29.5	25.7	15.8	12.0	10.0	8.68	7.52	6.67	6.03	5.52	5.05	2.87
1.80V/cell	54.9	42.5	32.3	28.2	17.0	12.9	10.6	9.09	7.87	6.96	6.30	5.79	5.27	2.99
1.75V/cell	61.0	46.3	34.6	30.0	17.9	13.6	11.0	9.41	8.12	7.19	6.49	5.96	5.37	3.05
1.70V/cell	65.0	49.2	36.5	31.6	18.9	14.1	11.4	9.68	8.39	7.42	6.67	6.11	5.49	3.08
1.67V/cell	66.9	50.5	37.5	32.6	19.3	14.5	11.6	9.85	8.50	7.50	6.76	6.17	5.54	3.11
1.60V/cell	71.7	53.6	40.0	34.4	20.0	15.0	12.0	10.1	8.68	7.64	6.86	6.29	5.64	3.15

**DISCHARGE CHARACTERISTICS**  
**CARACTÉRISTIQUES DE DÉCHARGE**

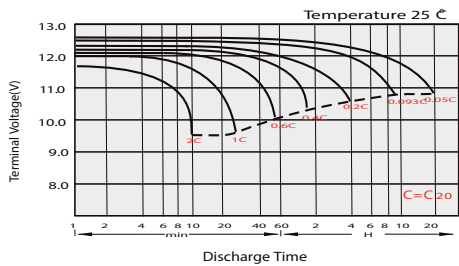

**FLOAT CHARGING CHARACTERISTICS**  
**CARACTÉRISTIQUES DE CHARGE EN FLOATING**

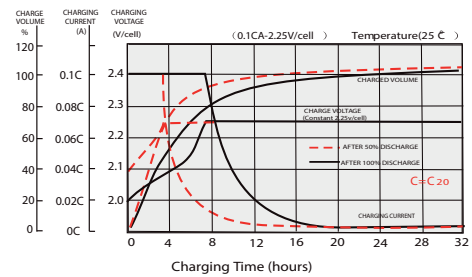

**TEMPERATURE EFFECTS IN RELATION TO BATTERY CAPACITY**  
**EFFET DE LA TEMPÉRATURE SUR LA BATTERIE**

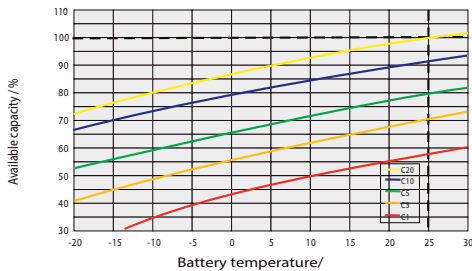

**CYCLE LIFE IN RELATION TO DEPTH OF DISCHARGE**  
**CYCLE DE VIE EN FONCTION DE LA PROFONDEUR DE LA DÉCHARGE**

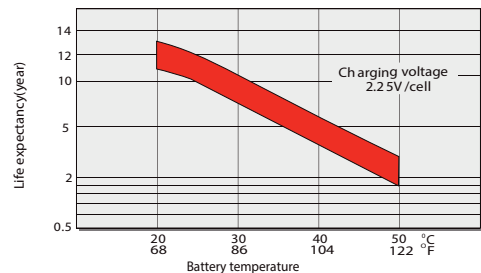

**CYCLE LIFE IN RELATION TO DEPTH OF DISCHARGE**  
**CYCLE DE VIE EN FONCTION DE LA PROFONDEUR DE LA DÉCHARGE**

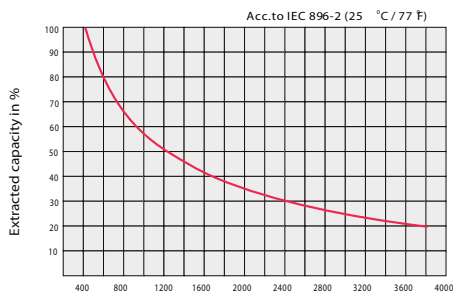

**SELF DISCHARGE CHARACTERISTICS**  
**RELATION ENTRE LA CAPACITÉ ET LE TEMPS DE STOCKAGE**

