



# ACCUS NIMH INDUSTRIELS H-F1AU PRISMATIQUE

## 1.2V 1.1Ah

### ELECTRICAL CHARACTERISTICS / CARACTÉRISTIQUES ÉLECTRIQUES

<b>NOMINAL VOLTAGE</b>	TENSION NOMINALE	1.2V
<b>MINI DISCHARGE VOLTAGE</b>	TENSION MINI EN DÉCHARGE	1V
<b>STANDARD CHARGE</b>	CHARGE STANDARD	110mA (16h)
<b>NOMINAL CAPACITY</b>	CAPACITÉ NOMINALE	1100mAh
<b>MINIMAL CAPACITY</b>	CAPACITÉ MINIMUM	1100mAh
<b>MAX CONTINUOUS DISCHARGE CURRENT</b>		2200mAh
<b>COURANT DE DÉCHARGE MAXI</b>		
<b>CYCLE LIFE AT 80% DOD (0,5C)</b>	DURÉE DE VIE À 80% DOD (0,5C)	500
<b>INTERNAL IMPEDANCE</b>	RESISTANCE INTERNE	28mΩ
<b>AMBIENT TEMPERATURE</b>	TEMPÉRATURE DE FONCTIONNEMENT	Standard charging: 0 to 45°C Discharging: -20°C to 50°C
<b>FAST CHARGE</b>	CHARGE RAPIDE	550mA
<b>TRICKLE CHARGE</b>	CHARGE DE MAINTIENT	33mA
<b>SELF DISCHARGE</b>	AUTO DÉCHARGE	≥ 825mAh at 25°C (% per month)



Unit: mm / Unité: mm

### PHYSICAL CHARACTERISTICS / CARACTÉRISTIQUES PHYSIQUES

DIMENSIONS	DIMENSIONS	
• Length / Longueur		66.3mm ±0.5mm
• Width / Largeur		16.5mm ±0.5mm
• Height / Hauteur		6mm ±0.3mm
WEIGHT	POIDS	25g

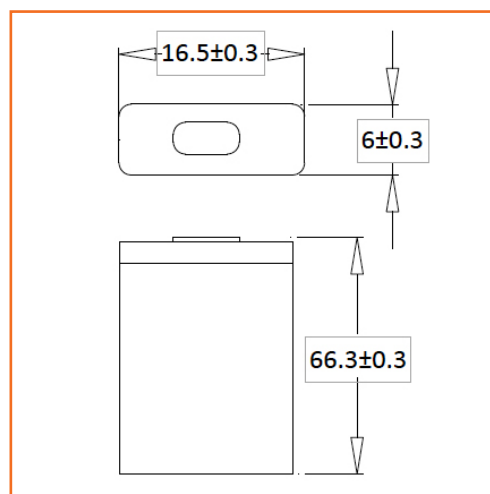

**0.2C RATE CHARGING CURVES**  
**COURBES DE CHARGE (0.2 C)**

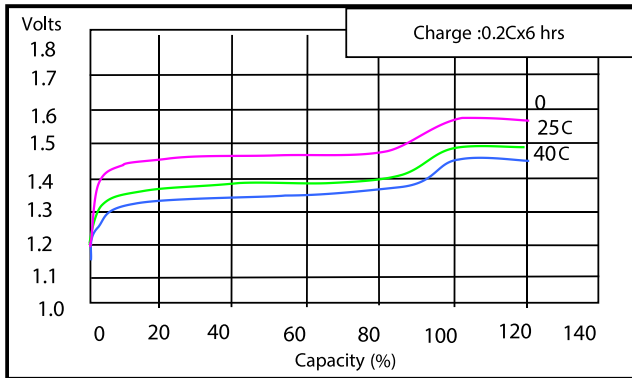

**0.1C / 0.2C RATE CHARGING CURVES**  
**COURBES DE CHARGE (0.1C / 0.2C)**

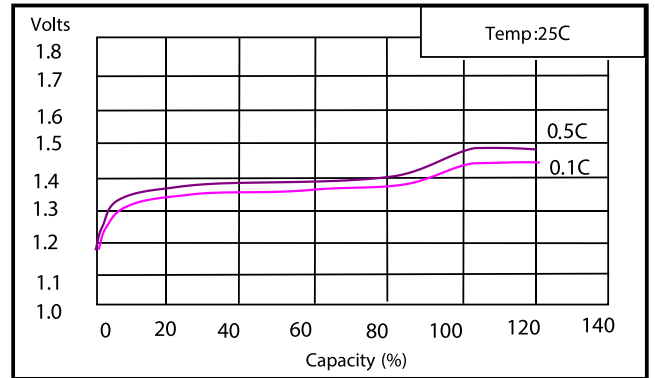

**0.1C / 0.5C / 1.0C RATE DISCHARGING CURVES**  
**COURBES DE DÉCHARGE (0.1C / 0.5C / 1.0C)**

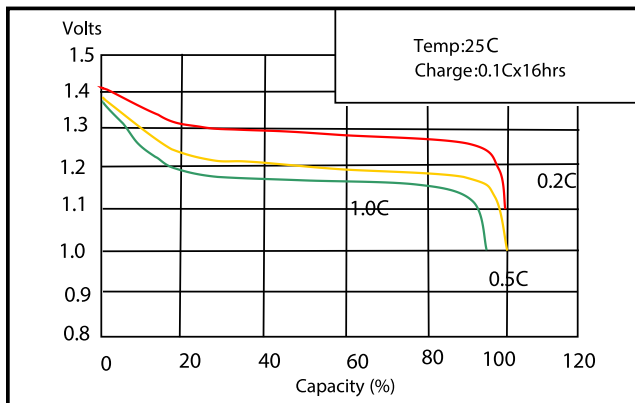

**STORAGE & SELF DISCHARGE CURVES**  
**COURBES DE STOCKAGE ET D'AUTODÉCHARGE**

