

# Instruction Manual for the use and the maintenance of battery and battery charger

Original instructions

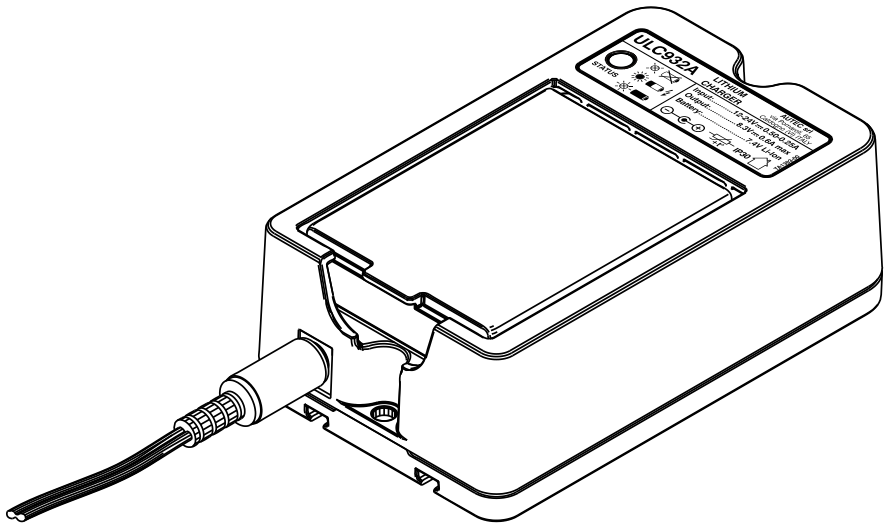

**Part E: LPM02 rechargeable battery  
ULC932A battery charger**

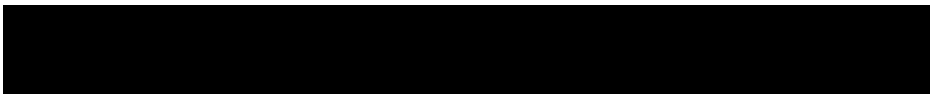





# WARNING

**THIS PART OF THE MANUAL CONSISTS OF: Part E - Information, instructions and warnings for the LPM02 rechargeable battery and for the ULC932A battery charger. The Manual consists of Part A – General, Part B – Conformity and Frequencies, Part C – Remote station, Part D – Base station and Part E – Battery and Battery Charger, plus the Technical Data Sheet.**

**THIS MANUAL, INCLUDING ALL PARTS THEREOF, AND ALL INSTRUCTIONS CONTAINED HEREIN, MUST BE READ CAREFULLY AND UNDERSTOOD BEFORE INSTALLING, USING, MAINTAINING OR REPAIRING THE AUTECCCS.**

**FAILURE TO READ AND COMPLY WITH ALL APPLICABLE WARNINGS AND INSTRUCTIONS OR ANY ONE OF THE LIMITATIONS NOTED IN THIS MANUAL CAN RESULT IN SERIOUS BODILY INJURY OR DEATH, AND/OR PROPERTY DAMAGE.**

**THE AUTECCCS IS NOT A STANDALONE PRODUCT AND IS INTENDED ONLY AS A COMPONENT ON A MACHINE:**

- ON WHICH AND WHERE THE USE OF A CCS IS APPROPRIATE,
- THAT CAN BE OPERATED SAFELY AND IN ACCORDANCE WITH ALL APPLICABLE LAWS, REGULATIONS AND STANDARDS BY SUCH REMOTE CONTROL.

**ACCORDINGLY, IT IS THE RESPONSIBILITY OF THE MACHINE MANUFACTURER ON WHICH THE AUTECCCS IS INTENDED TO BE INSTALLED, to perform an in-depth and accurate risk assessment to determine if the Autec CCS is suitable for operating a Machine in conditions of safety and operational effectiveness, taking into account the conditions of use, the intended uses and the reasonably foreseeable incorrect ones, so that the installation, maintenance and use of the Autec CCS, and all its components, are performed only and entirely in compliance with this Manual and in accordance with all local regulations, safety standards and regulations (referred to herein as "Laws, Regulations and Standards").**

**With reference to the USA market the Laws, Regulations and Standards include all safety rules and regulations of the Occupational Safety & Health Administration (OSHA) (<http://www.osha.gov>), all federal, state and local laws, regulations and building and electrical codes, and all applicable standards, including but not limited to ANSI Standards.**

**It is also the responsibility of the Manufacturer and of the design professionals of the Machine on which the Autec CCS is to be installed and used to be certain that the structure, condition, organization and markings of the Machine as installed at the facility is appropriate for and will allow for the safe and reliable use and control of the Machine through the Autec CCS interface.**

**IT IS THE RESPONSIBILITY OF THE OWNER AND FACILITY OPERATOR, AND THEIR DESIGN PROFESSIONALS, that the installation, maintenance and operation of the Autec CCS and all of its components are done solely and completely in accordance with this Manual, and with all applicable Laws, Regulations and Standards, even local. It is also the responsibility of the Manufacturer of the Machine on which the Autec CCS is to be installed and used, and their design professionals, to be certain that the structure, condition, organization and markings of the Machine as installed at the facility is appropriate for and will allow for the safe and reliable use and control of the Machine through the Autec CCS interface.**

**ONLY QUALIFIED AND PROPERLY TRAINED PERSONNEL SHOULD BE PERMITTED TO OPERATE OR USE THE AUTEC CCS AND THE MACHINE OPERATED BY OR THROUGH THE AUTEC CCS. ONLY QUALIFIED AND PROPERLY TRAINED PERSONNEL SHOULD BE PERMITTED TO BE IN THE VICINITY OF MACHINE OPERATED BY OR THROUGH THE AUTEC CCS.**

**FAILURE TO PROPERLY INSTALL, OPERATE, MAINTAIN AND SERVICE THE AUTEC CCS CAN RESULT IN SERIOUS BODILY INJURY OR DEATH AND/OR PROPERTY DAMAGE. Refer to this Manual and each of its Parts for further assistance or contact Autec. Autec is not responsible for and shall not be held liable for any installation of the Autec CCS not performed by Autec or for any use of the Autec CCS not in complete compliance with, and/or not maintained in complete compliance with, all Autec instructions and warnings and all applicable Laws, Regulations and Standards, even local.**

**Autec is not responsible for and shall not be held liable for any alteration or modification of the Autec CCS, or the use of non-Autec components or products used with or incorporated into the Autec CCS.**

**IT IS THE RESPONSIBILITY OF THE OWNER AND FACILITY OPERATOR, AND THEIR DESIGN PROFESSIONALS, to be certain that the Autec CCS is properly maintained and serviced at all times in compliance with all Autec instructions and warnings, and with all applicable Laws, Regulations and Standards, even local.**

**IT IS THE RESPONSIBILITY OF THE OWNER AND FACILITY OPERATOR, AND THEIR OFFICERS, MANAGERS AND SUPERVISORS, to be certain that all Users of the Autec CCS and that all Persons who are or will be working with or near the Machine operated by or through the Autec CCS are fully and properly educated and trained by qualified Personnel in the proper and safe use of the Autec CCS and of the Machine, including without limitation complete familiarity with and understanding of Autec warnings and instructions, and all applicable Laws, Regulations and Standards, even local, and that such Users and other Persons do in fact at all times operate or work with the Autec CCS safely and ONLY in compliance with Autec instructions and warnings and with all applicable Laws, Regulations and Standards, even local. FAILURE TO DO SO CAN RESULT IN SERIOUS BODILY INJURY OR DEATH AND/OR PROPERTY DAMAGE.**

**IT IS THE RESPONSIBILITY OF THE OWNER AND FACILITY OPERATOR, AND THEIR OFFICERS, MANAGERS AND SUPERVISORS, to be certain that the areas in which the Machine operated by or through the Autec CCS is located and operates are clearly delineated and marked in accordance with all Autec warnings and instructions, and all applicable Laws, Regulations and Standards, even local, and otherwise sufficient to alert and warn ALL PERSONS that the Machine is operated by or through a CCS, and prohibiting any unauthorized access thereto. FAILURE TO DO SO CAN RESULT IN SERIOUS BODILY INJURY OR DEATH AND/OR PROPERTY DAMAGE.**

**FAILURE TO OPERATE THE AUTEC CCS SAFELY AND IN COMPLIANCE WITH AUTEC INSTRUCTIONS AND WARNINGS AND WITH APPLICABLE LAWS, REGULATIONS AND STANDARDS, EVEN LOCAL, AND/OR PERMITTING USERS OR OTHER PERSONS NOT PROPERLY TRAINED IN THE SAFE AND PROPER USE OF THE SYSTEM, OR THE MACHINE ON WHICH IT IS INSTALLED, CAN RESULT IN SERIOUS BODILY INJURY OR DEATH AND/OR PROPERTY DAMAGE.**



# INDEX

<b>1</b>	<b>Information on the use of instructions</b>	<b>8</b>
1.1	Structure of the Instruction Manual	8
1.2	Caption and terminology	10
1.3	Symbols	10
1.4	To whom the instructions are addressed	11
1.5	Instruction storage	11
1.6	Intellectual property	11
<b>2</b>	<b>Brief product presentation</b>	<b>12</b>
2.1	Battery and battery charger	12
2.2	Conformity with standards	12
2.3	Contacts and useful addresses	13
2.4	Warranty	13
2.5	Technical assistance and spare parts	13
<b>3</b>	<b>LPM02 rechargeable battery</b>	<b>14</b>
3.1	Technical data	14
3.2	Plate	14
3.3	Warnings for use	15
3.4	First aid	16
3.5	Instructions for use	17
3.6	Storage	17
3.7	Shipping and transportation	18
3.8	Battery disposal	19
<b>4</b>	<b>ULC932A battery charger</b>	<b>19</b>
4.1	Technical data	20
4.2	Plates	20
4.3	Electrical connection	21
4.4	Positioning	22
4.5	Warnings for use	23
4.6	Instructions for use	24
4.7	Disposal	25
<b>5</b>	<b>Malfunctions</b>	<b>26</b>

## 1 Information on the use of instructions

	Before reading this part of the Manual, you must read and understand the general part (Part A) of the Manual provided with the CCS.
---	---

### 1.1 Structure of the Instruction Manual

The Manual for the use and maintenance of Autec CCSs consists of different parts, that altogether form the Manual; the Manual must be read carefully, understood and applied by the CCS's Owner, User and by all those Persons that, for any reasons, may operate with the CCS or with the Machine where it is installed.

The following table describes the structure of the Instruction Manual for the use and the maintenance of the CCS.

Part	Title	Contents
A	General part	<ul style="list-style-type: none"> <li>- General information regarding the series,</li> <li>- directions for risk assessment of the "Machine+CCS" system,</li> <li>- warnings for installation of the CCS,</li> <li>- warnings for use and maintenance of the CCS,</li> <li>- instructions for correct transportation and storage of CCS.</li> </ul>
B	Conformity and frequencies	<ul style="list-style-type: none"> <li>- Operating frequency bands of the CCS,</li> <li>- conformity and law references of the CCS.</li> </ul>
C	Remote station	Description and instructions concerning the Remote station, including: <ul style="list-style-type: none"> <li>- description of operation,</li> <li>- commands,</li> <li>- light signals,</li> <li>- malfunctions,</li> <li>- additional instructions to the general part.</li> </ul>
D	Base station	Description and instructions concerning the Base station, including: <ul style="list-style-type: none"> <li>- description of operation,</li> <li>- light signals,</li> <li>- malfunctions,</li> <li>- additional instructions to the general part.</li> </ul>
E	Battery and battery charger	Description, warnings and instructions concerning batteries and battery chargers, including: <ul style="list-style-type: none"> <li>- description of operation,</li> <li>- light signals,</li> <li>- malfunctions,</li> <li>- instructions for the User.</li> </ul>

Usage and maintenance instructions are supplemented by the CCS's Technical Data Sheet, that:

- Describes the Remote station's configuration
- Indicates the relation between commands sent by the Remote station and those available on the Base station.

Usage and maintenance instruction as a whole are to be considered as an integral part both of the Autec CCS and of the Machine, system, device or Machinery system where the CCS is installed.

The Manufacturer of the Machine on which the Autec CCS is installed, and the Owner and User of the Machine, must make sure that the Instruction Manual and all of its parts are included in the Instruction Manual of the Machine.

## 1.2 Caption and terminology

	<p>Contact Autec if any of the instructions, symbols, warnings or images are not clear and understandable.</p>
---	--

In this part of the Manual, the terms listed below have the same meaning explained in the corresponding paragraph of the general part (Part A):

- **Station**
- **CCS**
- **Remote station**
- **Base station**
- **Machine**
- **Manufacturer**
- **Installer**
- **User**
- **Maintenance Technician**
- **Manual or Instruction Manual**
- **Installation manual**
- **Person**
- **Owner**

Functions indicated for the Manufacturer, the Installer, the User and the Maintenance Technician may be performed by a single Person, if he/she has the needed competence and undertakes the resulting responsibilities. Each Person must be aware of the instructions contained in the Manual, depending on the activity they carry out.

For example, if a Manufacturer is also the Installer, and/or Maintenance Technician, he/she must also know and follow the instructions specifically addressed to those Persons. The same applies, for example, if a User is also the Manufacturer and/or the Installer.

## 1.3 Symbols

	<p>This symbol identifies the parts of text in the Manual that must be read with special attention.</p>
---	---

	<p><b>This symbol identifies the parts of text in the Manual containing warnings, information and/or instructions that are particularly relevant with regards to safety; failure in understanding them or in complying with them may cause hazards for People and/or property.</b></p>
---	--

#### **1.4 To whom the instructions are addressed**

---

Addressees of instructions are listed in the paragraph with the same title in the general part: please refer to that part.

#### **1.5 Instruction storage**

---

Regulation for the storage of instructions are described in the paragraph with the same title in the general part: please refer to that part.

#### **1.6 Intellectual property**

---

Restrictions connected to intellectual property are described in the paragraph with the same title in the general part: please refer to that part.

## **2 Brief product presentation**

---

### **2.1 Battery and battery charger**

---

The object of this part of the Manual is the LPM02 battery, that is meant to be used inside an Autec CCS's Remote station, and the corresponding ULC932A battery charger, that is needed to recharge it.

### **2.2 Conformity with standards**

---

#### **2.2.1 Conformity of LPM02 battery**



The LPM02 rechargeable battery complies with the EMC Directive (2014/30/EU) and with the following harmonised standards: EN 61000-6-2 and EN 61000-6-3.



The LPM02 rechargeable battery complies with the Electromagnetic Compatibility Regulations 2016 and with the following standards: EN 61000-6-2 and EN 61000-6-3.

#### **2.2.2 Conformity of ULC932A battery charger**



The ULC932A battery charger complies with the EMC Directive (2014/30/EU) and with the following harmonised standards: EN 55014-1, EN 55014-2, EN 61000-3-2, EN 61000-3-3, EN 61000-6-2 and EN 61000-6-3.



The ULC932A battery charger complies with the Electromagnetic Compatibility Regulations 2016 and with the following standards: EN 55014-1, EN 55014-2, EN 61000-3-2, EN 61000-3-3, EN 62233, EN 60335-1, EN 60335-2-29.



The ULC932A battery charger complies with the ECE R10-05 regulation, approval number E49 10R-050055.

This device complies with part 15 of the FCC Rules.

Operation is subject to the following two conditions:

- (1) this device may not cause harmful interference, and
- (2) this device must accept any interference received, including interference that may cause undesired operation.

### **2.3 Contacts and useful addresses**

The CCSs are produced by Autec Srl – Via Pomaroli, 65 - 36030 Caldogno (VI) - Italy. You can find contacts for Autec, its distributors, dealers and authorized service centres on the website [www.autecsafety.com](http://www.autecsafety.com).

### **2.4 Warranty**

General warranty conditions are indicated both in the relevant sheet provided together with this documentation, and in the specific page on the website [www.autecsafety.com](http://www.autecsafety.com).

### **2.5 Technical assistance and spare parts**

If you need technical services and/or spare parts, please refer to contacts provided in the website [www.autecsafety.com](http://www.autecsafety.com).

### 3 LPM02 rechargeable battery

The LPM02 rechargeable battery is used to provide power to Autec Remote stations with compatible battery housing (please check this in "Part C" of the Instruction Manual).

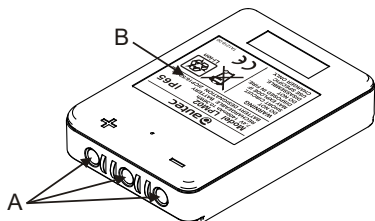

A	Contacts
B	Technical data plate

#### 3.1 Technical data

Type	Li-ion
Voltage	7.4V---
Capacity	1400mAh
Typical recharge time (with battery charger ULC932A)	2h 40min
Max. recharge time	4h
Recharge temperature	from +5°C to +45°C (from +41°F to +113°F)
Usage temperature	from -20°C to +55°C (from -4°F to +131°F)
Protection degree	IP65

#### 3.2 Plate

A plate is stuck on the battery, showing battery's identification, main technical data, marking and marks (if any).

	<p>The plate must not be removed from its position; removal will immediately void the warranty.</p> <p>The plate must not be altered or damaged: contact Autec for replacement.</p>
--	---

### 3.3 Warnings for use

Only use original Autec batteries and only recharge batteries with battery chargers and/or power supply units provided by Autec.

Never use damaged batteries (e.g. crushed, punctured, swollen or leaking batteries).

Never use batteries if they have been dropped even just once, as their internal components may have been damaged, even though this cannot be seen from the outside.

Improper use of batteries may pose the hazard of fire, explosion, overheating or other hazards. In particular, avoid the following:

- short-circuiting battery contacts;
- disassembling, cutting, opening, pressing, deforming, drilling, modifying, tampering with batteries or attempting to repair them in any way;
- trying to insert objects in the battery;
- immersing or exposing batteries in/to water or other liquids;
- placing the battery inside or on heating devices (e.g. ovens, heaters, radiators);
- placing the battery within high pressure containers;
- exposing the battery to impacts and drops;
- mouthing batteries (e.g. bite, suck it).

Do not carry loose batteries in a pocket or purse together with metal objects (like keys, coins, paper clips). This can short-circuit the battery, leading to high heat and causing burns.

Do not charge, use or store the battery at temperatures exceeding the limits provided in paragraphs 3.1 and 3.6.

The LPM02 battery cannot be used by People with reduced physical, sensory or mental capabilities, and by children.

Do not leave the battery under charge if the charge cycle does not end within the "Max. recharge time" (see paragraph 3.1).

Do not expose the battery to heat sources or fire. For example, do not expose it to direct sunlight for a long time, and pay special attention to high temperatures that may be reached inside unshaded vehicles.



 WARNING	<p><b>Do not attempt to repair damaged or faulty batteries.</b></p> <p><b>Keep the battery clean and dry. Pay special attention to the battery's contacts: if they get dirty, clean them with a non-abrasive cloth or brush, and a cleaner for electrical contacts.</b></p> <p><b>It is forbidden to recharge the battery in explosion-risk areas where gases and/or dusts are present.</b></p> <p><b>The battery must be charged in the "SAFE AREA", i.e. without explosion-risk gases and/or dusts.</b></p>
--	---

Autec cannot be held responsible for any use that does not comply with the provisions and directions provided in the Manual, and for any damage that may result from improper, incorrect or irrational use of the battery.

### 3.4 First aid

 WARNING	<p><b>If the battery or part of it is swallowed, immediately seek medical advice.</b></p> <p><b>If a Person comes into contact with material leaking from a damaged battery, immediately wash the affected part with soap and water for at least 15 minutes and seek immediate medical advice.</b></p>
--	--

### 3.5 Instructions for use

	<p>Charge the battery before first use.</p> <p>The use of altered batteries or batteries that are not the original ones will void any warranty both of the battery and of the Remote station.</p>
---	---

In order to ensure the maximum battery life over time, please respect the following preventive measures:

- Do not use or recharge the battery at temperatures exceeding the limits provided in paragraph 3.1.
- Follow the storage instructions provided in paragraph 3.6.
- Do not expose the battery to heat sources.

Batteries may be recharged and discharged several times, but progressive reduction of the maximum capacity, and therefore shorter run time of the battery normally occur with prolonged use.

Partial charging/discharging does not damage the battery.

### 3.6 Storage

Please note that if a battery is not used, it will self-discharge over time; long-lasting storage may also lead to the complete and permanent loss of capacity, thus making the battery unusable. If you expect not to use the battery for a long time, it is recommended to store it in a cool and dry place, in order to ensure its maximum lifetime.

Do not store flat batteries. In this case, self-discharge may drop the battery to such a low charge level that it will no more be possible to recharge it.

The following table shows the residual battery capacity in comparison to its nominal value, depending on the storage temperature and period.

Temperature range	Period	Residual capacity
from 45 to 60°C (from 113 to 140°F)	1 month	75%
from 25 to 45°C (from 77 to 113°F)	3 months	70%
from -20 to 25°C (from -4 to 77°F)	1 year	80%

This table refers to a battery stored at half charge (voltage between 7.5V and 7.7V), which is the ideal condition for storage. Batteries stored at half charge will last at least three times more than batteries stored at full charge.

For example, if storing at a temperature from -20 to 25°C (from -4 to 77°F), it is recommended to run a charge-discharge cycle of the battery every 90 days. After each charge-discharge cycle, bring the battery back to the ideal half charge condition before storing it again.

To obtain the half-charge condition, you can perform the following procedure:

1. Discharge the battery by means of the Remote station until it indicates that the battery is low (see "Light signals" in "Part C" of the Instruction Manual): in such conditions the open circuit voltage measured at the battery poles will be about 7 V.
2. Insert the battery in a powered battery charger.
3. Remove the battery after about 65min.
4. Make sure that the battery voltage is within 7.5V and 7.7V.

 WARNING	<p><b>Do not expose the battery to direct sunlight for a long time.</b></p> <p><b>Do not store fully charged or flat batteries for a long time.</b></p>
--	---

	<p>After long idle periods, it may be needed to carry out several battery discharge/charge cycles to achieve the best performance.</p>
---	--

### **3.7 Shipping and transportation**

---

	<p>Refer to standards UN 3480 and UN 3481 to ship and transport Li-ion batteries.</p>
---	---

### 3.8 Battery disposal



**Do not dispose of batteries with domestic trash and do not burn them as they may explode.**

Batteries may contaminate the environment due to toxic or harmful substances that can be dangerous for humans, animals and the vegetation. For this reason, they must not be disposed of as unsorted household waste. They must be brought to the appropriate collection point for the collection, recycling and treatment of batteries.

Users participation in the collection and recycling of batteries is important to reduce to the minimum any potential impacts of substances used in these components on the environment and on human health.

#### 3.8.1 Directive 2006/66/EC and amendments

Different collection and recycling schemes for batteries are established across the European Union. For any information on the schemes valid in your area, please contact the relevant local authorities in your territory.

The crossed-out wheeled bin marked on batteries indicates that they must be disposed of separately from household waste, in conformity with the EU Directive 2006/66/EC and its amendments, and with local regulations.

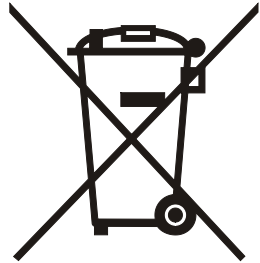

## 4 ULC932A battery charger

The ULC932A battery charger is used to charge the LPM02 rechargeable battery used in Autec CCSs.

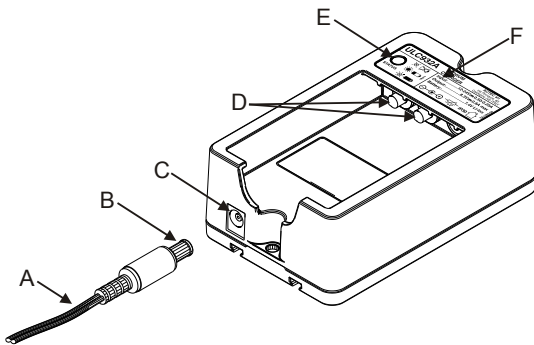

A	Power supply cable
B	Jack plug
C	Socket
D	Contacts
E	LEDs
F	Technical data plate

## 4.1 Technical data

---

Power supply voltage	12-24V=
Absorbed current	0.5-0.25A
Output voltage	8.3V
Max. output current	0.6A
Resettable fuse	1.1A
Typical recharge time	see paragraph 3.1
Max. recharge time	see paragraph 3.1
Recharge temperature	see paragraph 3.1
Protection degree	IP30
Dimensions	70x113.5x39.5mm (2.76x4.47x1.56in)

## 4.2 Plates

---

Technical and identification data of battery charger ULC932A are provided in the plate on the front of the device, where the signalling LED is; approval data are provided in the plate stuck on the back.

	<p>Plates must not be removed from their position: removal immediately voids the warranty.</p> <p>Plates must not be altered or damaged, contact Autec for replacement.</p>
---	---

### 4.3 Electrical connection

The ULC932A battery charger can be powered by a 12/24V battery, with a power supply unit equipped with safety isolating transformer or with the mains adapter provided by Autec.

	<p><b>Never use the battery charger and/or the mains adapter if they are damaged.</b></p> <p><b>The mains adapter that comes with the battery charger is protected against short circuit. If power supply is provided by a 12/24V battery or by a power supply unit equipped with safety isolating transformer, make sure that they are protected against short circuit.</b></p> <p><b>Check that the battery charger power supply voltage is within the limits given in the "Technical data".</b></p> <p><b>Place the battery charger in a position that allows to easily reach and remove the supply cable (jack plug).</b></p>
---	---

	<p>It is good practice to connect the battery charger to the power source only when recharging the battery. Once the charging has been completed, disconnect the battery charger from the power supply.</p>
---	---

#### 4.4 Positioning

	<p><b>Place the battery charger in an indoor and dry place, far from liquids, dust and heat sources.</b></p> <p><b>Do not place the battery charger in explosion-risk areas where gases and/or dusts are present.</b></p> <p><b>The battery charger must be placed in the "SAFE AREA", i.e. without explosion-risk gases and/or dusts.</b></p> <p><b>Leave at least 5cm (1.97In) room above and around the battery charger.</b></p> <p><b>Do not set any objects on the battery charger when it is connected to the mains.</b></p> <p><b>Do not in any case perforate, modify or tamper with the battery charger.</b></p>
---	---

Battery charger ULC932A is generally used horizontally, but it can also be mounted vertically by using the appropriate holes on its case and fixing it with screws (max. 4mm/0.16In diameter). It is also possible to fix the power supply cable so that it will not be torn: when fixing the device, place the cable as shown in the figure.

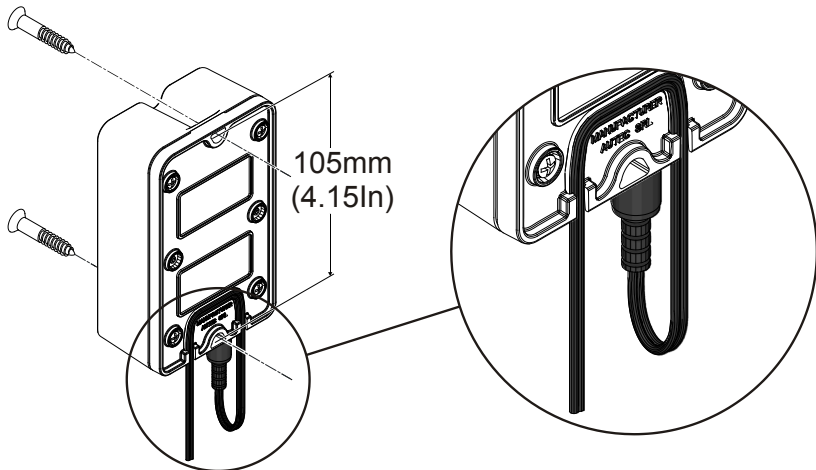

## 4.5 Warnings for use

Users of battery chargers must respect the following behavioural rules and preventive measures.

 <p>WARNING</p>	<p><b>This equipment cannot be used by people with reduced physical, sensory or mental capabilities and by children.</b></p> <p><b>This equipment is for professional use only, and cannot be used by unskilled people, unless they are supervised and have received instructions on the use of this device by a Person in charge for their safety.</b></p> <p><b>Do not handle the battery charger and/or the mains adapter with wet or damp hands or feet or using objects, tools and/or implements that conduct electricity, are not insulated or are not protected from the risk of electrical conduction; do not in any case use damaged or wet objects and/or tools.</b></p> <p><b>Disconnect power supply, disconnect the jack plug and remove the battery (if present) before any cleaning or maintenance operation.</b></p> <p><b>Check that the contacts are intact and clean before inserting the battery in the battery charger. If necessary, clean them with a non-abrasive cloth or brush and a generic electrical contact cleaner.</b></p> <p><b>The ULC932A battery charger can only recharge Autec original LPM02 rechargeable batteries: any different use is considered improper and therefore dangerous.</b></p> <p><b>Improper use of battery chargers and/or mains adapters may cause fire, explosion, overheating or other hazards.</b></p> <p><b>Use of the device with a battery other than an original one may jeopardise its function and safety.</b></p> <p><b>In case of breakage due to fall, squashing or other events, do not attempt to repair the battery charger: please contact the support service of the Machine Manufacturer.</b></p> <p><b>Avoid the deposit of materials (such as concrete, sand, lime, conductive dust...) on the battery charger, because they can compromise its use and safety.</b></p>
--	---

Autec cannot be held responsible for any use that does not comply with the provisions and directions provided in the Manual, and for any damage that may result from improper, incorrect or irrational use of the battery charger and/or of the mains adapter.

## 4.6 Instructions for use

### 4.6.1 Light signals

The status of battery charger ULC932A is indicated by the white STATUS LED. The meaning of light signals is indicated by symbols on the battery charger's technical data plate, near the LED.

Signals	Meaning
The STATUS LED blinks slowly.	The battery charger is powered. The battery is not inserted.
The STATUS LED is lit with a steady light.	The battery is being recharged.
The STATUS LED blinks fast.	The battery is charged.

### 4.6.2 Recharge procedure

Follow this procedure to recharge batteries.

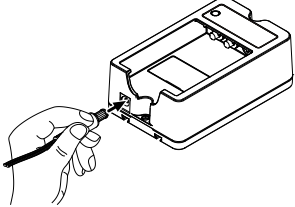
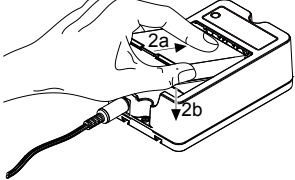
<p>1. Power the battery charger by plugging the jack plug in the battery charger's socket (LED blinks slowly).</p>	
<p>2. Push the battery towards the battery charger's contacts (2a) and insert it inside the housing (2b). Charging starts, and this is signalled by the LED lit with a steady light (see paragraph 3.1 "Typical charge time"). NOTE: do not force insertion. The battery slides easily into place and ensures that the positive (+) and negative (-) poles are correctly connected only if it is inserted with the plate facing the compartment, so that the battery's contacts match the battery charger's contacts.</p>	

The battery is fully charged when the LED blinks quickly.

3. Remove the battery: push the battery towards the battery charger's contacts (3a) and lift the battery (3b).

If necessary, it is possible to remove and use the battery even if it is partially charged (see paragraph 3.5).

If you leave the battery in the Battery Charger after charging has been completed, the charger may start charging for a brief period: a steady on LED will alternate to a fast blinking LED. This balances the charging level of the cells contained in the battery and/or compensates self-discharge (if any).

Do not, in any case, leave the battery under charge for prolonged time when it is not in use.

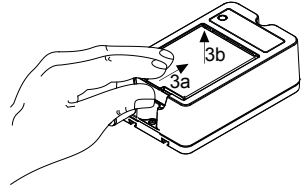

4. Disconnect power supply from the battery charger (the LED will go off).

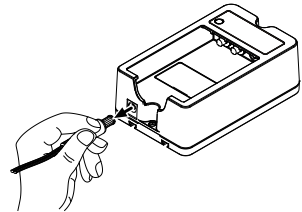

## 4.7 Disposal

When disposing of a battery charger, its components must be managed as separate waste. When disposing of a battery charger, please comply with the provisions and/or the regulations in force in the country where it is used.

## 5 Malfunctions

Damages to the battery charger or to the battery may be signalled when:

- one of the signals listed in the following table appears, or
- the LED signals does not reflect any of the cases listed in the table in paragraph 4.6.1 (check if the malfunction occurs with both the batteries provided: if the same result is obtained with both, you can assume that the battery charger is damaged; otherwise, the damage concerns one of the two batteries).

Signals	Possible reasons	Solutions
STATUS LED does not illuminate.	Resettable thermal fuse inside the battery has been triggered.	Disconnect power supply and connect again after 5 minutes.
	Battery charger is not powered correctly.	Make sure that the battery charger power supply is within the voltage limits indicated in the technical data (see paragraph 4.1). Make sure that the power supply protection against short circuit has not cut in. Correctly insert the power supply cable's jack plug into the battery charger's socket.
The STATUS LED blinks slowly with battery inserted.	Dirty contacts on the battery and/or on the battery charger.	Clean the contacts on the battery and on the battery charger with a non-abrasive cloth or brush and a generic electrical contact cleaner. Then charge the battery.
	The battery temperature is not within the "Charge temperature" range provided in paragraph 3.1.	Move the battery to a place whose temperature is within the "Charge temperature" range and allow it to stabilize. Then charge the battery.

Signals	Possible reasons	Solutions
The STATUS LED blinks slowly with battery inserted.	Check if the malfunction occurs with both the batteries provided: if the same result is obtained with both, it may be assumed that the battery charger is damaged; otherwise the damage concerns one of the two batteries.	Replace the battery charger or the battery.
The STATUS LED switches from slow blinking to fast blinking when the battery is inserted.	If this problem occurs when a flat battery is inserted, it may be assumed that the battery charger is damaged.	Replace the battery charger.
A charge cycle that does not end within the "Max. recharge time" (see paragraph 3.1).	Dirty contacts on the battery and/or on the battery charger.	Clean the contacts on the battery and on the battery charger with a non-abrasive cloth or brush and a generic electrical contact cleaner. Then charge the battery.
	The battery temperature is not within the "Charge temperature" range provided in paragraph 3.1.	Move the battery to a place whose temperature is within the "Charge temperature" range and allow it to stabilize. Then charge the battery.
	Check if the malfunction occurs with both the batteries provided: if the same result is obtained with both, it may be assumed that the battery charger is damaged; otherwise the damage concerns one of the two batteries.	Replace the battery charger or the battery.
Battery run time is significantly shorter than normal.	Dirty contacts on the battery and/or on the Remote station.	Clean the contacts on the battery and on the Remote station with a non-abrasive cloth or brush and a generic electrical contact cleaner. Then charge the battery.

<b>Signals</b>	<b>Possible reasons</b>	<b>Solutions</b>
Battery run time is significantly shorter than normal.	Check if the malfunction occurs with both the batteries provided: if the same result is obtained with both, it may be assumed that the battery charger is damaged; otherwise the damage concerns one of the two batteries.	Replace the battery charger or the battery.

If the problem persists after attempting the suggested solution, contact the support service of the Machine Manufacturer.









Via Pomaroli, 65 - 36030 Caldogno (VI) - Italy  
Tel. +39 0444 901000 - Fax +39 0444 901011  
info@autecsafety.com - www.autecsafety.com

MADE IN ITALY